

JENSEN®

How to Install the CM715K AM/FM Stereo Receiver/Cassette Tape Player/CD Player

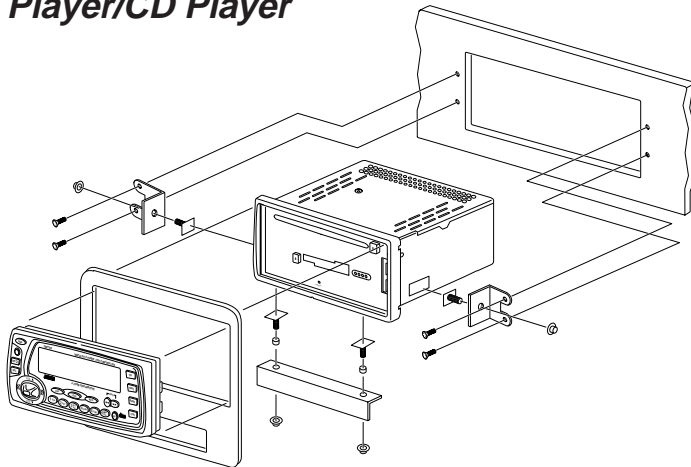

Welcome!

What you're holding in your hands is no ordinary owner's manual. We've tried to make the instructions in this book clear and easy to follow.

For your Jensen stereo to work right, it must be installed correctly. This manual will show you how to install your new stereo like a pro. It's a good idea to read all of these instructions before you begin the installation. Most installations are straightforward and can be handled by a do-it-yourselfer with the right tools, patience, and the ability to follow instructions. But, do-it-yourself installation isn't for everyone. If you still don't feel confident after reading this book, consider turning the installation job over to someone better suited to it.

Warranty Service

If your Jensen stereo should ever require service, you will need to have the original dated receipt. If you ever need to return the unit for any reason, always include the receipt with the product.



Technical Assistance

For technical assistance with the installation of the CM715K, call 1-800-323-0221.

Installation

Contents

Installation	2
Before You Begin Installation	2
Tools and Supplies Needed	2
Speaker Requirements	2
Prepare Radio for Installation	2
Adapters for Easier Installation	2
• Connections	3
• Crimp Connections	3
• Upgrading your System	3
Disconnect Battery	4
Remove Old Radio	4
Wiring	5
• Fuse Adapters	5
Wiring with a Wiring Adapter	6
Connect Wires	6
Wiring Color Codes	6
Attach Wires to Radio	6
Install Wiring Inside the Car	6
Wiring Diagram—Advanced Installation	7
Testing	8
Reconnect Battery	8
Test Power Wiring	8
View/Set the Clock	8
Test Antenna Connection	8
Test Memory Wiring	8
Test Speaker Connections	9
• Balance	9
• Fader	9
Attach Brackets	10
• GM	10
• Dodge/Chrysler/Plymouth ..	11
• Jeep Grand Cherokee, Dodge Avenger, Plymouth Sebring	11
Troubleshooting	12
Reset Button	12
Specifications and Warranty	13

Installation

Before You Begin Installation

Before you begin, you will need tools, supplies and adapters. It is best to make sure you have everything you need before you take your dashboard apart.

Tools and Supplies Needed

Basic Installation:

- Flat and Phillips screwdrivers
- Wire cutters
- Wire strippers
- Tools to remove existing radio (screwdriver, socket wrench set or other tools)
- Electrical tape

Advanced Installation:

- Soldering iron
- Crimping tool
- 12 volt test light / Digital Meter
- Solder
- Crimp connectors
- 18 gauge wire for power connections
- Speaker wire

Speaker Requirements

Only connect the CM715K to speakers rated in the load impedance range of 4 to 8 ohms. Speakers with a load impedance less than 4 ohms could damage the CM715K.

Prepare Radio for Installation

Remove transport screws (you cannot insert a CD until the screws are removed)

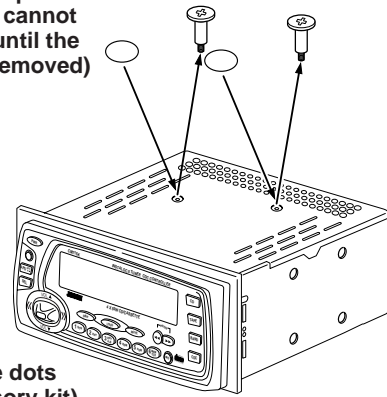

Put adhesive dots (from accessory kit) over transport screw holes

Adapters for Easier Installation

Electrical and dashboard adapters make installation easier. Purchase adapters from your local Jensen retailer, electronics store or car stereo specialty store.

Wiring Harness Adapter

For a basic installation, you can purchase a wiring harness adapter for your car's existing radio connectors. This makes installation easy.

Antenna Adapter (GM cars)

1990 and newer GM cars have a small antenna connector. You will need an adapter when installing this radio in a newer GM car.

Professional Tip

Connections

Good wire connections are very important for best sound and long-term reliability. Here are two methods:

Splice

1. Strip 1/2 inch (12 mm) of insulation from both wires.
2. Wrap wires together.
3. Fold wires over.
4. Stretch electrical tape tightly over splice.

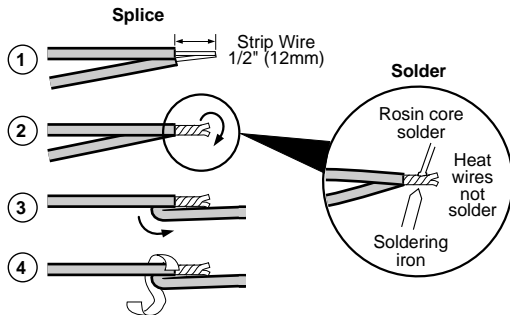

Solder

Solder is the best way to connect wires, but it takes skill and practice. Splice the wires (as shown above). Before taping, heat the wires (not the solder). When the wires are warm enough, touch the solder to the splice. The solder will flow over the wires. Stretch electrical tape tightly over splice.

Professional Tip

Crimp Connections

Purchase crimp connectors and crimping tool. Connectors are color coded. This Jensen radio uses BLUE connectors (14-16 gauge wire).

1. Strip 1/4 inch (6mm) of insulation from both wires.
2. Insert into connector.
3. Crimp tightly.

You can make permanent splices (using butt connectors) or select connectors that can be removed and reinstalled.

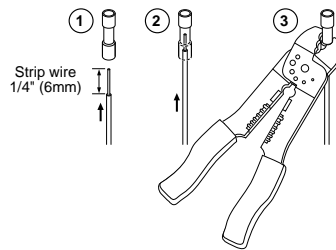

Professional Tip

Upgrading Your System

Jensen makes a wide range of car stereo products that will make your car system sound better, great or INCREDIBLE!

Better Sound

Install a Jensen tape deck or CD player like you're doing now. High power units can make your existing speakers sound better and play louder.

Great Sound

Replace your existing speakers with Jensen speakers. Many of our speakers will fit into your car without cutting or drilling. You can also add an amplified graphic equalizer to tailor the sound to your liking.

INCREDIBLE Sound

Jensen offers a full line of amplifiers, high-power speakers and subwoofers that can turn your car into audio dynamite. You can go loud, louder and loudest by selecting Jensen components from your retailer.

Disconnect Battery

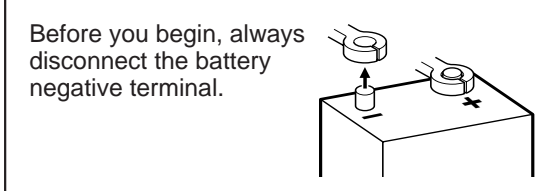

Remove Old Radio

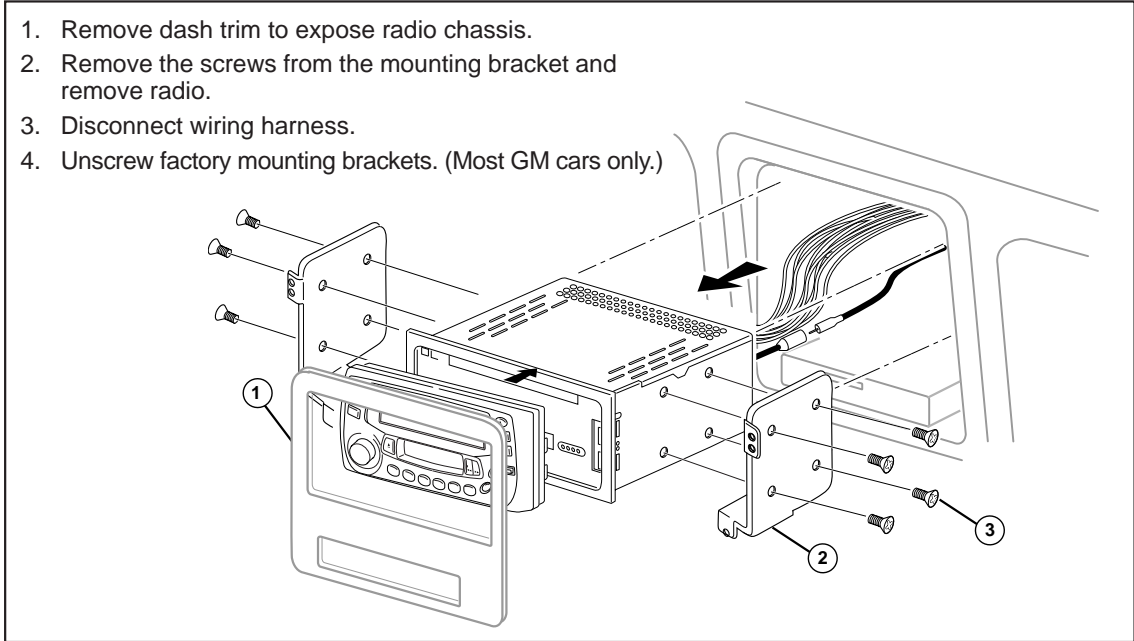



Wiring

Important

If wiring connections are made wrong, the unit will not operate properly and it could be damaged. Follow the installation instructions carefully, or have the installation handled by an experienced technician.

Professional Tip**Fuse Adapters**

No convenient power wire? Install a fuse adapter having a spade connector.

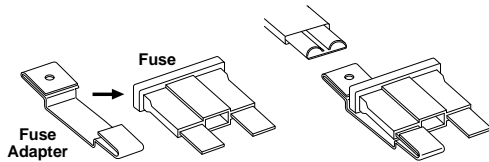

Crimp on a matching connector and attach:

- Yellow wire—Fuse marked MAIN, BAT or PWR
- Red wire—Fuse marked ACCY (accessory), or RADIO

Wiring with a Wiring Adapter

This is the easiest wiring method, because it replaces your existing radio. You will have to buy a wire harness adapter from your dealer, a car stereo installation shop or electronics store. If you use a wiring adapter, you can connect all wires to the radio before you even start to take your old radio out.

Connect Wires

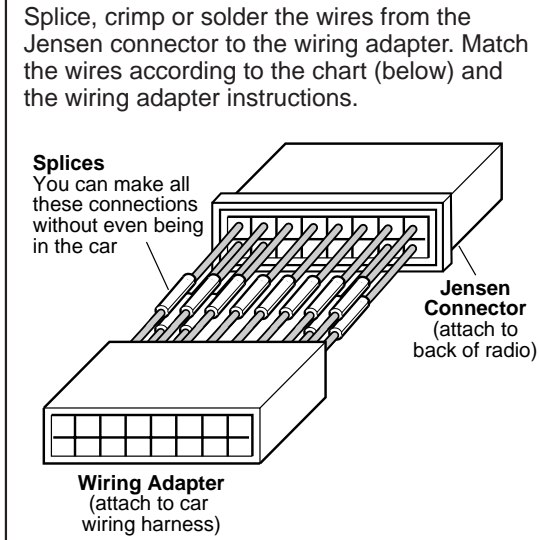

Wiring Color Codes

Function	Color
LF+ Speaker	white
LF- Speaker	white/black
LR+ Speaker	green
LR- Speaker	green/black
RF+ Speaker	gray
RF- Speaker	gray/black
RR+ Speaker	violet
RR- Speaker	violet/black
Power Antenna	dark blue
Ground	black
Ignition	red
Battery	yellow
Dimmer	orange
Cellular Mute	pink

Attach Wires to Radio

1. After splicing the wiring adapter to the Jensen connector, attach the connector to the back of the radio as shown.
2. Attach antenna extender cable (not supplied) and antenna adapter (if needed).

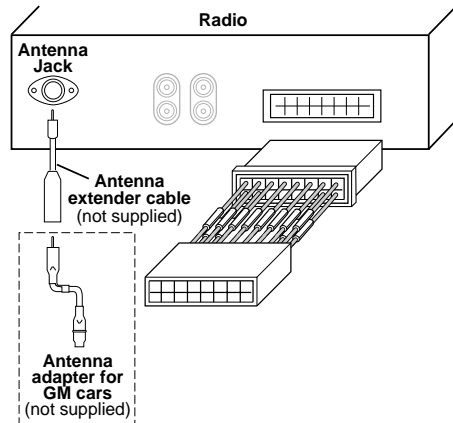

Install Wiring Inside the Car

1. Connect wiring adapter to the car's existing wiring harness.
2. Connect antenna extender cable (not supplied) to car antenna lead.

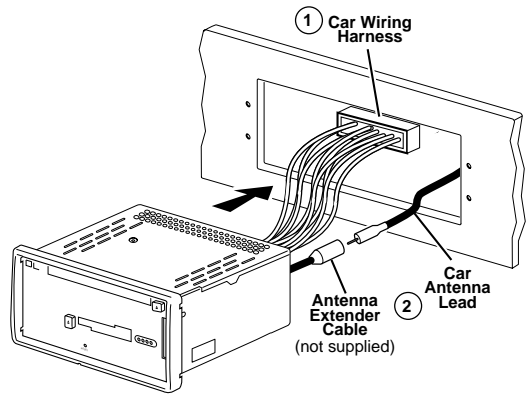

Go to "Testing" on page 8.

Wiring Diagram—Advanced Installation

If you are installing new speakers or amplifiers or replacing an aftermarket installation, use this diagram.

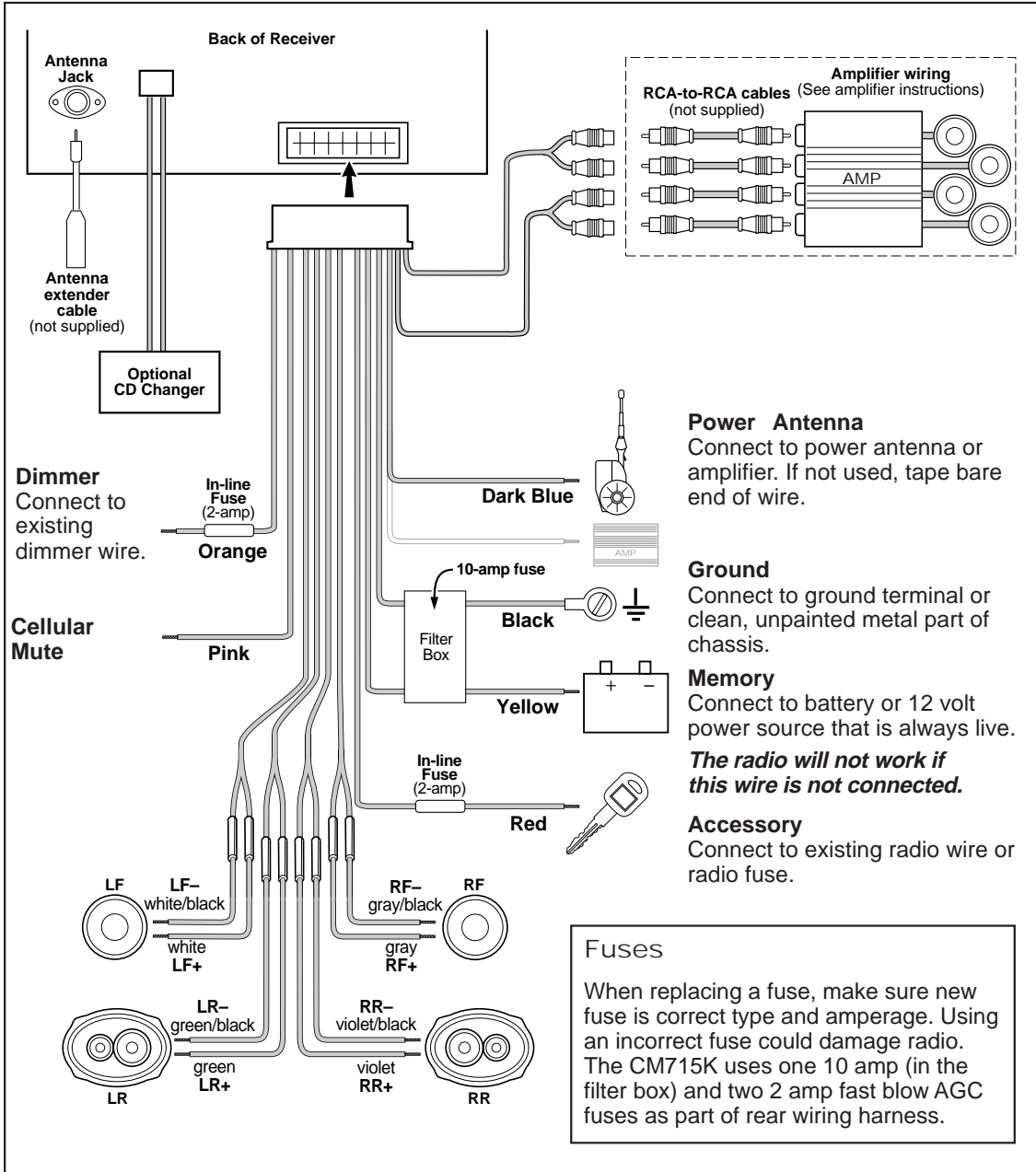

Go to "Testing" on page 8.

Testing

Before you finish the installation, you should do the following tests to make sure the wiring is correct and everything is operating properly.

Reconnect Battery

When wiring is complete, reconnect the battery negative terminal.

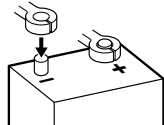



Test Power Wiring

1. Turn ignition switch on. The display should light. If not, check the electrical connection at the yellow and red wires.
2. Press **PWR** button to turn the receiver on. You will see the radio display. If not, check electrical connections to the red and yellow wires.
3. If equipped, the power antenna should also operate. If not, check electrical connections to the dark blue wire.

Set the Clock

Press **DISP** button to temporarily display clock.

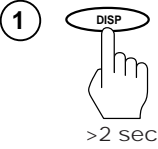
To set the clock:

1. Press and hold **DISP** button for more than two seconds. Colon will flash.
 
2. Within 3 seconds, press **»** on the control button to change the minutes and **«** to change the hours.
 

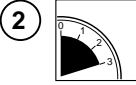
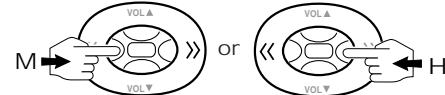
2.
 

Test Antenna Connection

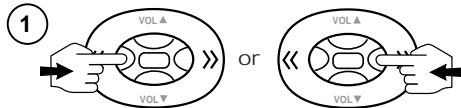

1. Press **«** or **»**. The radio should tune to a nearby station. If not, check antenna connection.

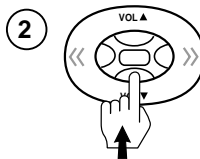

2. Press the **VOL ▲** button to increase volume until you can hear the radio playing.

Test Memory Wiring

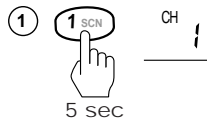

1. With the radio playing, hold button **1** for five seconds. CH 1 will appear in the display. You just stored the current station in memory.



2. Turn the key off, then turn the key on again.

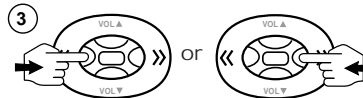

3. Press **«** or **»**. The radio will select a different station.

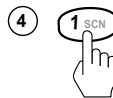



4. Press button **1** again. It should return to the station that was playing before (step 1). If not, make sure the yellow wire is connected properly.

Test Speaker Connections

These tests make sure the speakers are connected right. If speakers don't play at all, both wires may not be connected. If the wrong speaker plays (you hear front speakers when you expect rear speakers) make sure you connected the wires right.

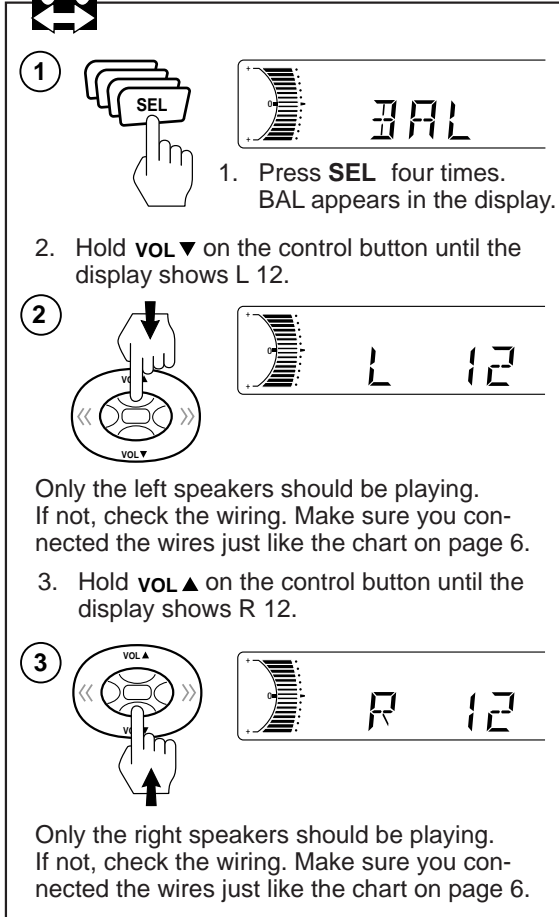
Balance



1   1. Press **SEL** four times. BAL appears in the display.

2. Hold **vol ▼** on the control button until the display shows L 12.

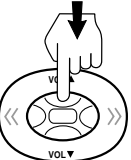
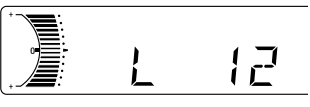
2   Only the left speakers should be playing. If not, check the wiring. Make sure you connected the wires just like the chart on page 6.

3. Hold **vol ▲** on the control button until the display shows R 12.

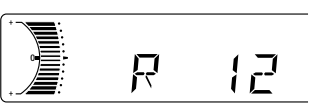

3   Only the right speakers should be playing. If not, check the wiring. Make sure you connected the wires just like the chart on page 6.

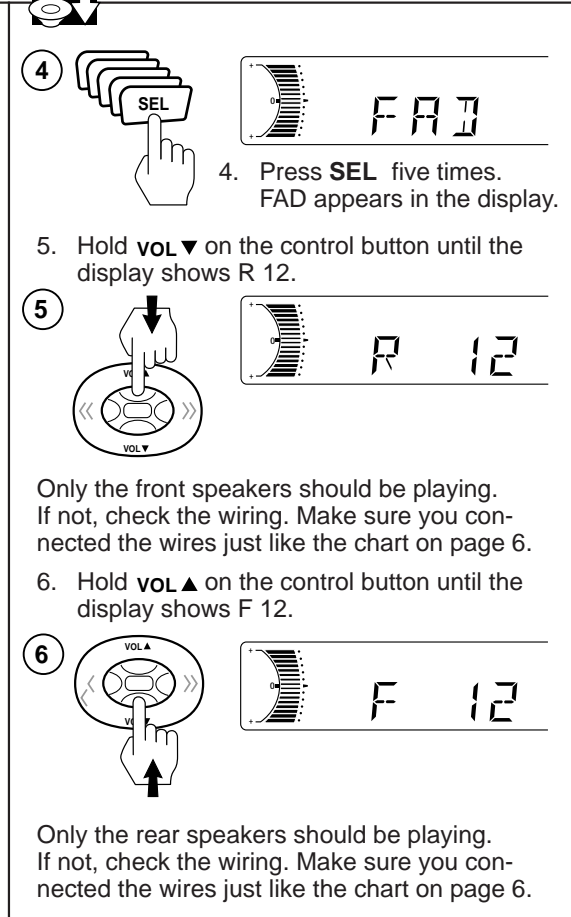
Fader

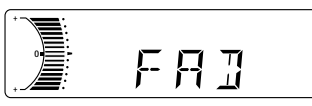

4   4. Press **SEL** five times. FAD appears in the display.

5. Hold **vol ▼** on the control button until the display shows R 12.

5   Only the front speakers should be playing. If not, check the wiring. Make sure you connected the wires just like the chart on page 6.

6. Hold **vol ▲** on the control button until the display shows F 12.

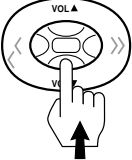
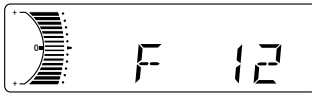
6   Only the rear speakers should be playing. If not, check the wiring. Make sure you connected the wires just like the chart on page 6.

Attach Brackets

GM

1. Note the position of brackets on the existing radio.
2. Remove the captive bolts and brackets from your existing radio and transfer to the same location on your new radio. (See Note.)

NOTE : The brackets supplied with your Jensen radio are designed for the following vehicles:

- 93-up Firebird/Camaro
- 94-up Bonneville
- 94-up Grand Prix
- 95-up Sunfire
- 96-up Grand Am

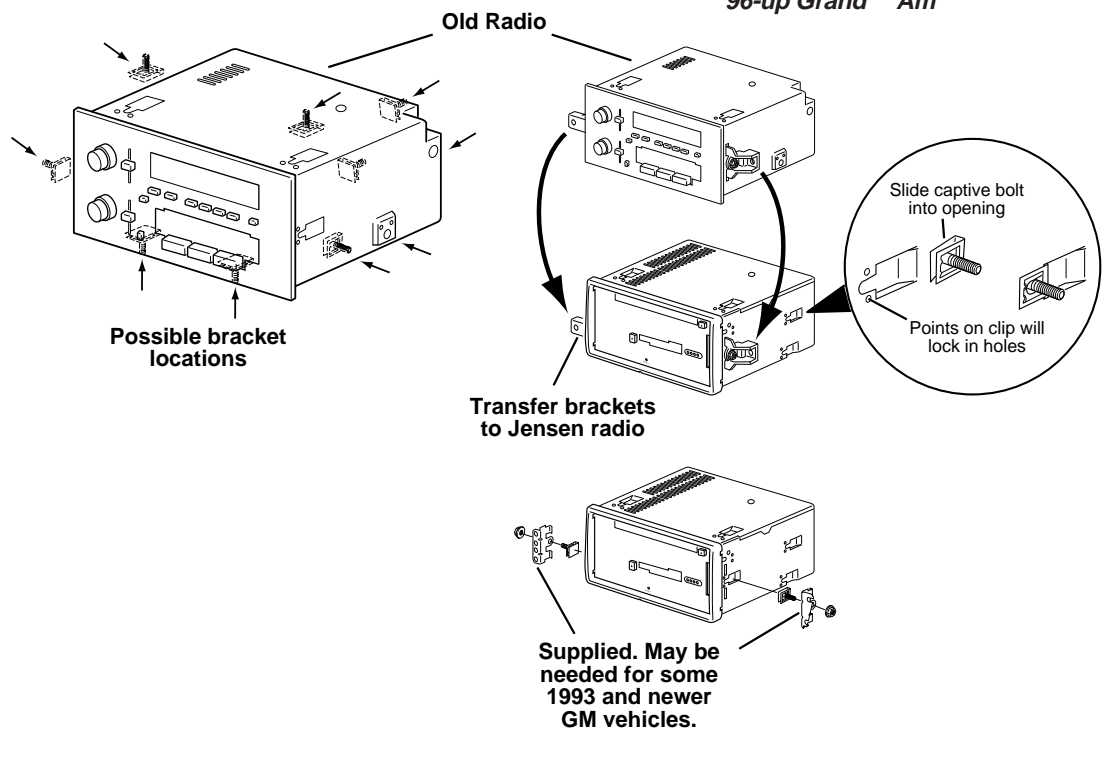

Dodge/Chrysler/Plymouth

1. Note the position of brackets on the existing radio.
2. Match the brackets found in the hardware kit to the mounting tabs on your factory radio.
3. Attach the supplied brackets to the chassis of the radio with the four "machine thread" Phillips type screws. Use two screws for each bracket.

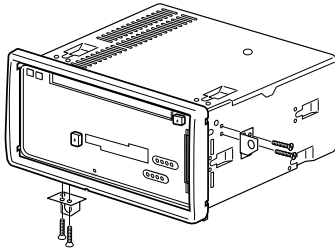
Typical Bracket Location**Jeep Grand Cherokee, Dodge Avenger, Plymouth Sebring**

1. Note the position of brackets on the existing radio.
2. Match the brackets found in the hardware kit to the mounting tabs on your factory radio.
3. Attach the supplied brackets to the chassis of the radio with the four "machine thread" Phillips type screws. Use two screws for each bracket.

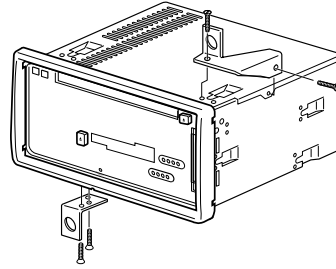

Troubleshooting

Problem	Cause	Corrective Action
Does not operate (display does not light)	No power to yellow wire No power to red wire	Check connection Check vehicle fuse
	Inline fuse blown	Replace fuse
Not all speakers operate	Incorrect splices or connections	Check all splices and connections
	Speaker wires shorting to chassis ground or to each other	Check splices, insulate all bare wires
Blows fuses	Power wire shorting to ground	Insulate wire
	Speaker wires shorting to ground	Insulate wire
	Incorrect fuse	Install fuse of correct rating
ER-1 appears on display	Disc reading malfunction	Try a different disc. The disc may be damaged or dirty
ER-2 appears on display	Disc loading or eject malfunction	Press RESET button Insert a disc and try again
ER-3 appears on display	High temperature	Wait until temperature returns to normal
Can't find cause of problem		Call Jensen Technical Assistance (1-800-323-0221)

Reset Button

In case of abnormal operation:
Use a pencil tip (or other non-metallic object) to press the **RESET** button.

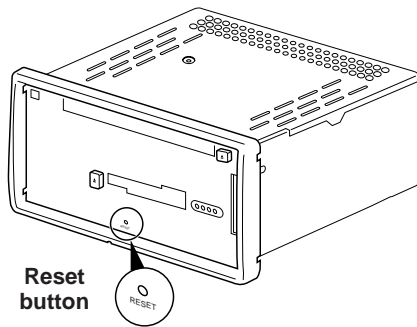



Specifications

CD Player

Signal/noise ratio >86 dB
 Frequency response 20 Hz - 20 kHz
 Channel separation >65 dB
 D/A converter 1 Bit D/A

Tape Player

Frequency response ± 3 dB 50 Hz-15 kHz
 Wow & flutter13%Jis
 Signal/noise ratio (a-weighted) 65 dB

FM Tuner

Tuning range 87.5 MHz-107.9 MHz
 FM mono sensitivity 12 dBf
 50 dB quieting sensitivity (stereo) 16 dBf
 Stereo separation @ 1 kHz 40 dB

AM Tuner

Tuning range 530 kHz-1720 kHz

Amplifier

Total system power 160 watts peak
 Power output front: 2 x 40W
 rear: 2 x 40W

General

Power supply 11-16 VDC, negative ground
 Speaker output impedance 4-8 Ohms
 Fuses fast blow AGC (2 amp and 10 amp)

Specifications subject to change without notice.

Limited One Year Warranty-USA and Canada

Length of Warranty. This warranty from Recoton Mobile Electronics shall be in effect for a period of one year from the date of the first consumer purchase.

Persons Protected. This warranty will be enforceable by the original owner and any subsequent owners during the warranty period so long as proof of date of purchase from an authorized Jensen dealer is presented whenever warranty service is required.

What is Covered. Except as otherwise specified below, this warranty covers all defects in material and workmanship in this product. The following are not covered: damage resulting from accident, misuse, abuse, neglect, product modification, improper installation, incorrect line voltage, unauthorized repair or failure to follow instructions supplied with the product; damage occurring during shipment (claims must be presented to the carrier); elimination of car static or other electrical interferences; any product purchased outside USA or Canada, or on which the serial number has been defaced, modified or removed.

How You Can Get Service.

U.S. Purchasers. Please telephone Jensen at 1-800-323-4815. We will either inform you of the name and address of an authorized Jensen repair station which will service the product or will advise you to send the product to a factory service center.

Canadian Purchasers. The product should be returned to the Jensen dealer from whom it was purchased and such dealer either will service or arrange for service of the product.

If shipment of the product is required, it should be packed securely. The original dated bill of sale must always be included with the product as proof of warranty coverage.

What We Will Pay For. We will pay for all labor and material expenses required to repair the product, but you must pay any labor costs for the removal and/or installation of the product. If the product is shipped for warranty service, you must prepay the initial shipping charges, but Jensen will pay the return shipping charges if the product is returned to an address inside the USA or Canada.

Limitation of Implied or Statutory Warranties and

Conditions. All implied or statutory warranties and conditions, including warranties or conditions of merchantability, fitness for particular purposes and non-infringement, are limited in duration to the length of this warranty.

Exclusion of Certain Damages. Jensen's liability is limited to the repair or replacement, at our option, of any defective product and shall not include incidental or consequential economic damages of any kind.

Some states and/or provinces do not allow limitations on how long an implied warranty lasts and/or do not allow the exclusion or limitation of incidental or consequential damages, so the above limitations and exclusions may not apply to you.

This warranty gives you specific legal rights, and you may also have other rights which vary from state to state and province to province.

Recoton Mobile Electronics
 A Division of Recoton Audio Corporation
 A RECOTON® COMPANY
 1090 Emma Oaks Trail
 Lake Mary, Florida 32746
 ©1999 Recoton Audio Corporation